

**Hydronix**

Digital Microwave Moisture Sensor  
for Bulk Solids and Liquids

# Hydro-Mix XT

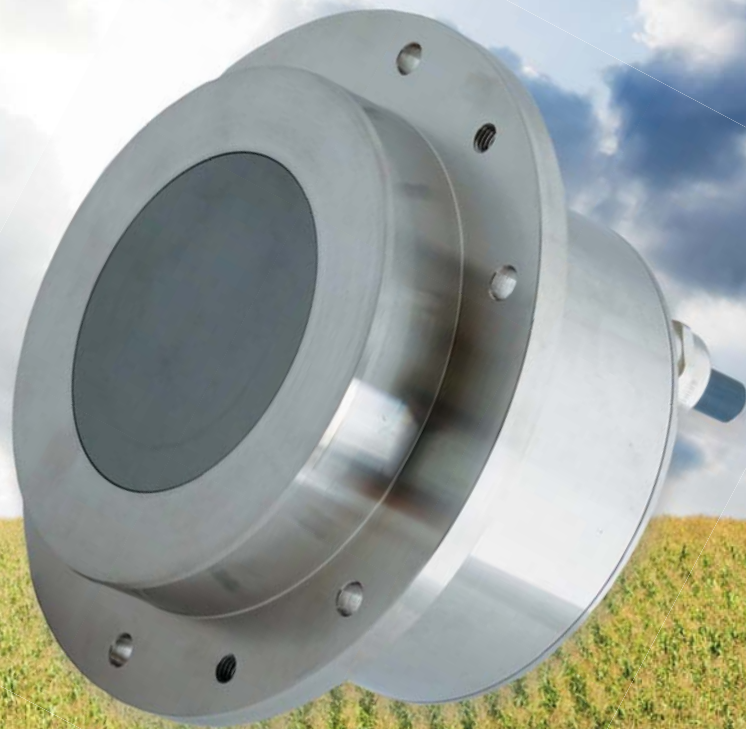

GRAIN : FEED : NUTS : GRANULES : LIQUIDS

# Hydro-Mix XT

## Flush mount, digital microwave moisture sensor

The Hydro-Mix XT has been designed to measure moisture in flowing bulk solids such as animal feed, grain, rice, pulses and also in liquids. The sensor is constructed from food safe materials and can be easily installed in ducting, conveying and mixing systems in process control environments.

Comprising a single, intelligent unit that contains all on-board functionality including signal processing, smoothing and averaging, the Hydro-Mix XT accurately measures the moisture content of material passing over the ceramic faceplate. Remote configuration, calibration, diagnostics and firmware upgrades are simple using Hydronix Hydro-Com software. The linear output allows direct integration with any control system using industry standard interfaces.



## Features

- Compact, self-contained unit
- Manufactured from food safe materials.
- Fixing Plate seal enables installation in dusty or liquid processes or applications.
- Designed for installation in a pressurised environment.
- Digital measurement technology provides precise linear moisture measurement with 25 readings per second.
- Advanced Digital Signal Processing provides a clear signal with rapid response.
- Fully temperature compensated measurement.
- Two analogue outputs, digital RS485 communications and configurable digital inputs/output, alarms.
- Remote communication with Hydro-Com software allows configuration of all sensor parameters.
- Consistent performance with no need for recalibration except for use with different materials.

## Mixer / Conveyor Installation

Fixing Plate for simple installation



## Typical Installation into Mixers or Conveyors

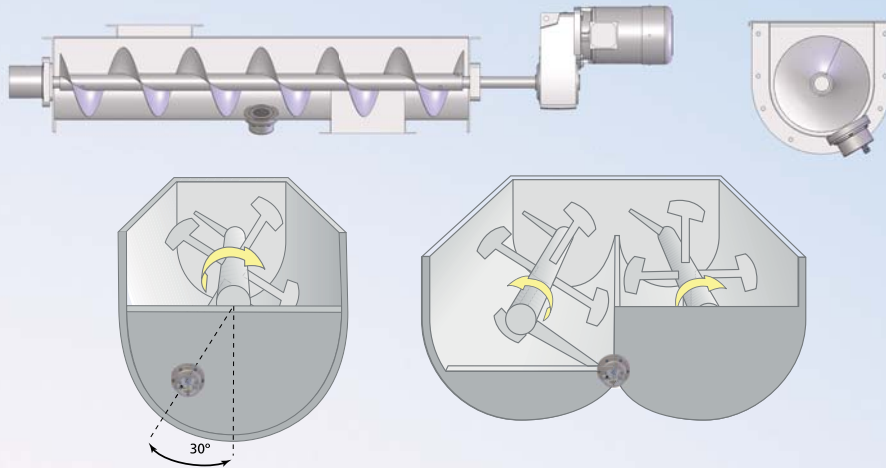

The Hydro-Mix XT can be mounted in many different locations where there is a continuous flow of material across the ceramic faceplate. These include drying, ducting, conveying and mixing systems.

## Installation into Ducting

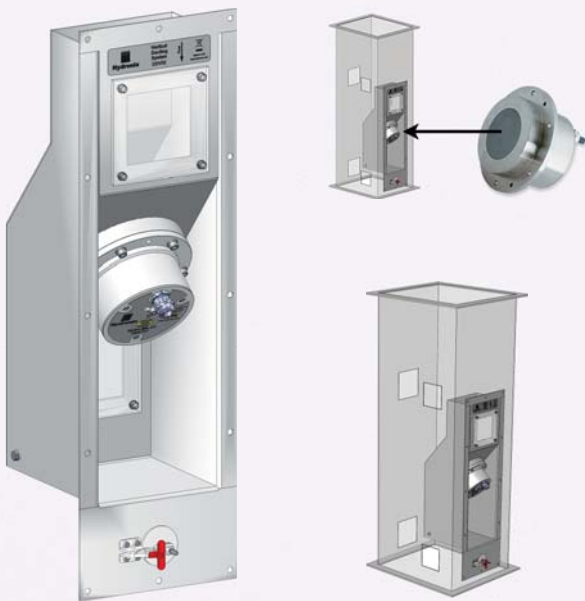

Hydronix has developed a ducting system for the Hydro-Mix XT sensor. This makes it simple to install the sensor in exactly the right position to achieve the most precise moisture measurement results. Hydronix recommends that our system is used in all ducting applications as it will easily allow us to support the Hydro-Mix XT.

The Hydronix Ducting System is a stainless steel unit that diverts a portion of the flowing material across the measuring surface of the sensor. This provides a consistent and stable flow of material that is required to accurately measure moisture.

The system can be installed into either new or existing ducting and comes in two versions, a vertical system or an angled system (30°-50° to the vertical) providing a choice of installation options.

## Display and Control Options

Hydronix has a range of display and control options

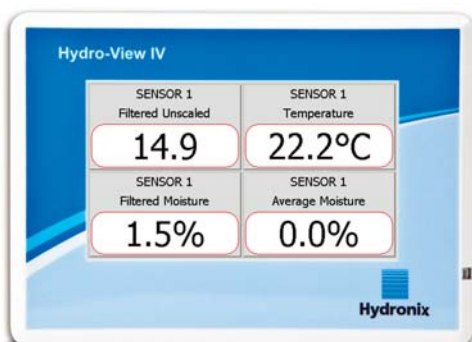

## Configure and Calibrate

Easily configure and calibrate the sensor using Hydro-Com Software



# Technical Information

## Construction

Body: 316 Stainless Steel (Food Safe).

Faceplate: Ceramic (Food Safe).

Internal Seals: EPDM FDA Approved O-Rings.

Fixing Plate O-Ring: EPDM FDA Approved

## Fixing

The sensor is flush mounted with the internal wall of the installation using the included mounting assembly.

## Measurement Range

Moisture: 0-100%, material dependant.

Depth: Approx. 75-100mm, material dependant.

## Measurement Modes

Choice of modes for optimising sensor performance

## Operating Temperature

### Process:

Continuous 0-60°C.

## Refresh Rate

25 times per second

## Analogue Outputs

Two configurable 4-20mA or 0-20mA current loop source available for moisture and temperature. May also be converted to 0-10V DC.

## Digital Inputs/Output

Two configurable digital signals available for averaging and alarm functions.

## Digital (Serial) Communication

Opto-Isolated RS485 2-wire port.

RS232 converter, Ethernet and USB interfaces available.

Programming details to access sensor values and parameters are available on request.

## Environmental

Pressure: 1 Bar Vacuum to 5 Bar pressure.

Protection: Cable Gland IP68.

## Integrated Cable

4m, six twisted pairs, 22AWG, 0.35mm<sup>2</sup> conductors. Screen braid with 65% minimum coverage plus aluminium/polyester foil. Maximum recommended cable run of 100m. Extension cables available.

## Power Supply

+15V to +30V DC, 4W.

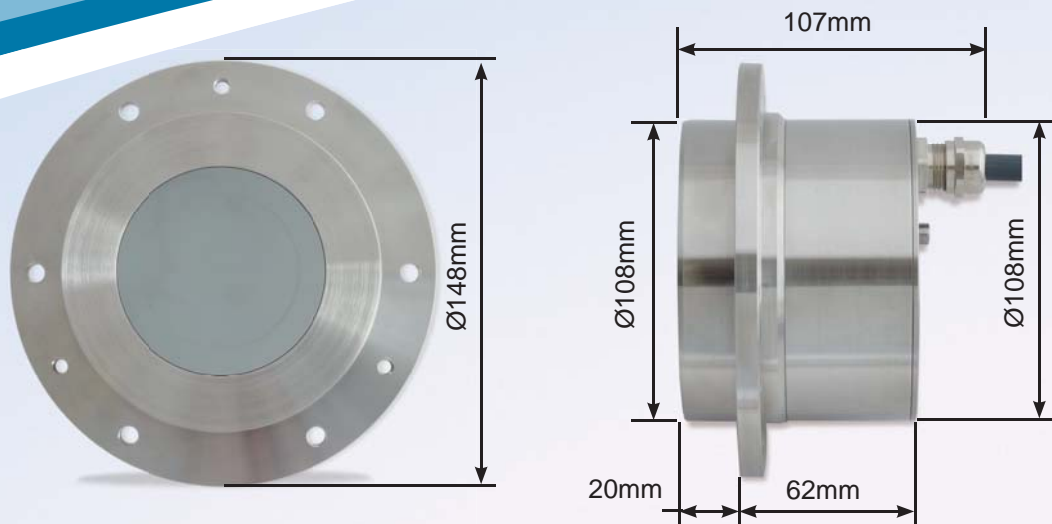

Part Number	Description
HMXT-01	Hydro-Mix XT Digital Microwave Moisture Sensor
DSV02	HMXT Ducting System - Vertical
DSA02	HMXT Ducting System - Angled
5010	HMXT Fixing Plate Kit (Fixing Plate, Bolts and O-Ring), required
5015	HMXT Fixing Plate (includes Fixing Plate Bolts)
5020	HMXT Fixing Plate O-Ring
5025	HMXT Fixing Plate Bolts
0116	Power Supply 30 Watt for up to 4 sensors
0049A	RS232-485 Converter - DIN rail mounting
0049B	RS232-485 Converter - 9 pin D-type to terminal block
SIMxx	USB Sensor Interface Module including cables and power supply
EAK01	Ethernet Adapter Kit
EPK01	Ethernet Power Kit
HMXTEW	4 Year extended warranty option



# Hydronix

## Head Office - United Kingdom:

Tel: +44 (0)1483 468900

Fax: +44 (0)1483 468919

Email: enquiries@hydronix.com

## Central Europe & Southern Africa:

Tel: + 49 2563 4858

## France:

Tel: + 33 652 04 89 04

## America, Spain & Portugal:

Tel: +1 231-439-5000

[www.hydronix.com](http://www.hydronix.com)